

UNOFFICIAL COPY

RETURN TO: RAE BODONYI
RECORDING REQUESTED BY:
1507 LEAR INDUSTRIAL PARKWAY, UNIT 2
AVON, OHIO 44011
440-778-1820

CUSTOMERSERVICE@LRSINC.COM

Prepared By: Johann Nkr
~~WHEN RECORDED MAIL TO:~~

Sprint Contracts & Performance
Mailstop KSOPHT0101-Z2650
6391 Sprint Parkway
Overland Park, Kansas 66251-2650



Doc#: 1003203001 Fee: \$42.00
Eugene "Gene" Moore RHSP Fee: \$10.00
Cook County Recorder of Deeds
Date: 02/01/2010 09:54 AM Pg: 1 of 4

[space above this line for Recorder's use]

LR# 98269

MEMORANDUM OF FIRST AMENDMENT TO SITE LEASE ACKNOWLEDGEMENT

THIS MEMORANDUM OF FIRST AMENDMENT TO SITE LEASE ACKNOWLEDGEMENT ("Amended Memorandum"), by and between Emergency Service, Inc., an Indiana corporation ("Lessor") and SprintCom, Inc., a Kansas corporation ("Lessee"), evidences that the lease made and entered into by written instrument between Lessor and Lessee or Lessee's affiliate, dated November 14, 1997 ("Agreement"), has been amended by written instrument between the parties (the "Amendment"). No instrument has been previously recorded with the County of Cook to memorialize the Agreement.

The Amendment provides in part that Lessor leases to Lessee a portion of real property located at 500 North Skokie Boulevard, Village of Northbrook, County of Cook, State of Illinois, together with non-exclusive utility and access easements (the "Site") as further described in Exhibit A, attached hereto. The Amendment extends the term of the agreement for five (5) years commencing on December 1, 2007, with one (1) additional 5-year renewal option.

IN WITNESS WHEREOF, the parties have executed this Amended Memorandum as of the day and year indicated below.

LESSOR:

Emergency Radio Service, Inc.

By: [Signature]
Name: Bridget Hill
Title: VP & GM
Date: 7/23/08

LESSEE:

SprintCom, Inc.

By: [Signature]
Name: Jon L. Geisel
Title: Supervisor, Contract Negotiations
Date: July 18, 2008

UNOFFICIAL COPY

Sprint Site ID: CH03XC242-C

**EXHIBIT A
TO MEMORANDUM OF FIRST AMENDMENT TO
SITE LEASE ACKNOWLEDGEMENT**

Site Description

Site situated in the Village of Northbrook, County of Cook, State of Illinois commonly described as follows:

500 Skokie Boulevard, Northbrook, Illinois 60062

PIN #: 64-02-402-030-0000

Legal Description:

LOT 2 IN LANE PARK SUBDIVISION IN THE SOUTH EAST ¼ OF SECTION 2, TOWNSHIP 42 NORTH, RANGE 12 EAST OF THE THIRD PRINCIPAL MERIDIAN, IN COOK COUNTY, ILLINOIS



Site Plan:

See Attached.

Lessor Initials: MA

Lessee Initials: W

UNOFFICIAL COPY

 Together with NEXTEL. 400 GRAND AVE. BARRACLET, IL 60009	 Alcatel-Lucent	 WAT WAT CONSULTING 1011 W. WASHINGTON ST. SUITE 200 CHICAGO, IL 60606	EAST E. THOMAS, P.E. P.L.S. LICENSED PROFESSIONAL ENGINEER LICENSE # 021-10103 Expires 11/28/02 Renewal:	PROJECT NO. 1003203001-08 DRAWN BY: JCL CHECKED BY: MAMA	4G: CH03XC063 HOST: CH03XC242 500 NORTH SKOKIE 500 SKOKIE BLVD NORTHBROOK, IL 60062	SHEET TITLE SITE PLANS	SHEET NUMBER C-1
---	---	--	---	--	---	---------------------------	---------------------

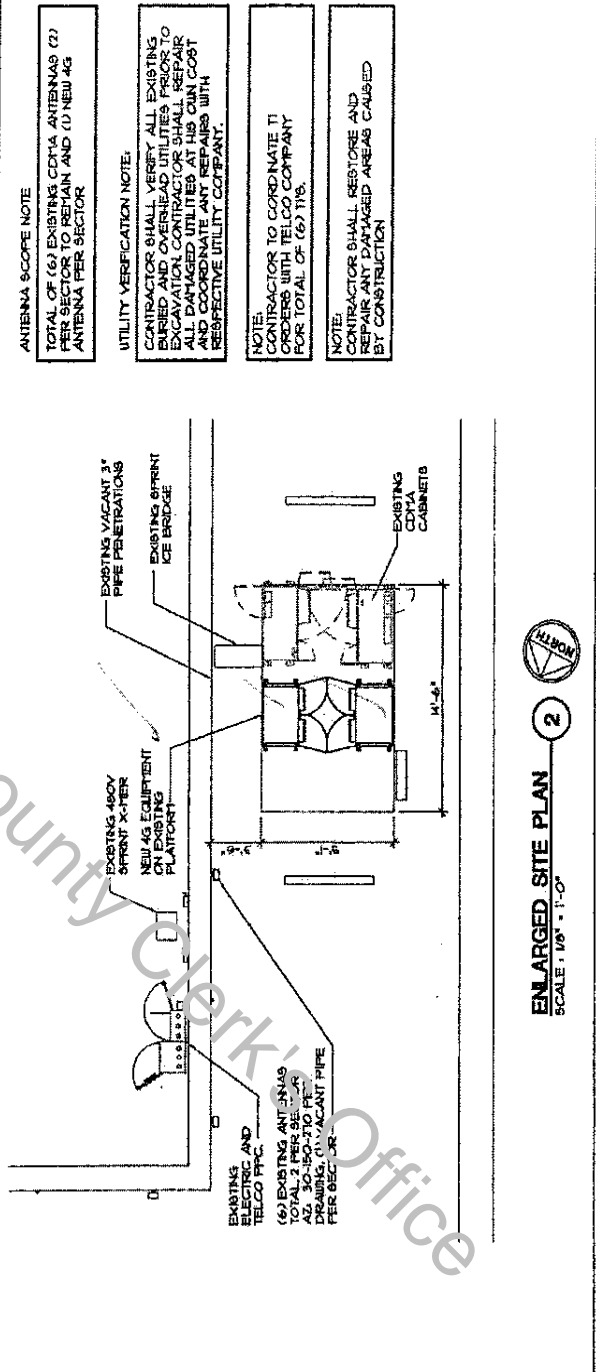
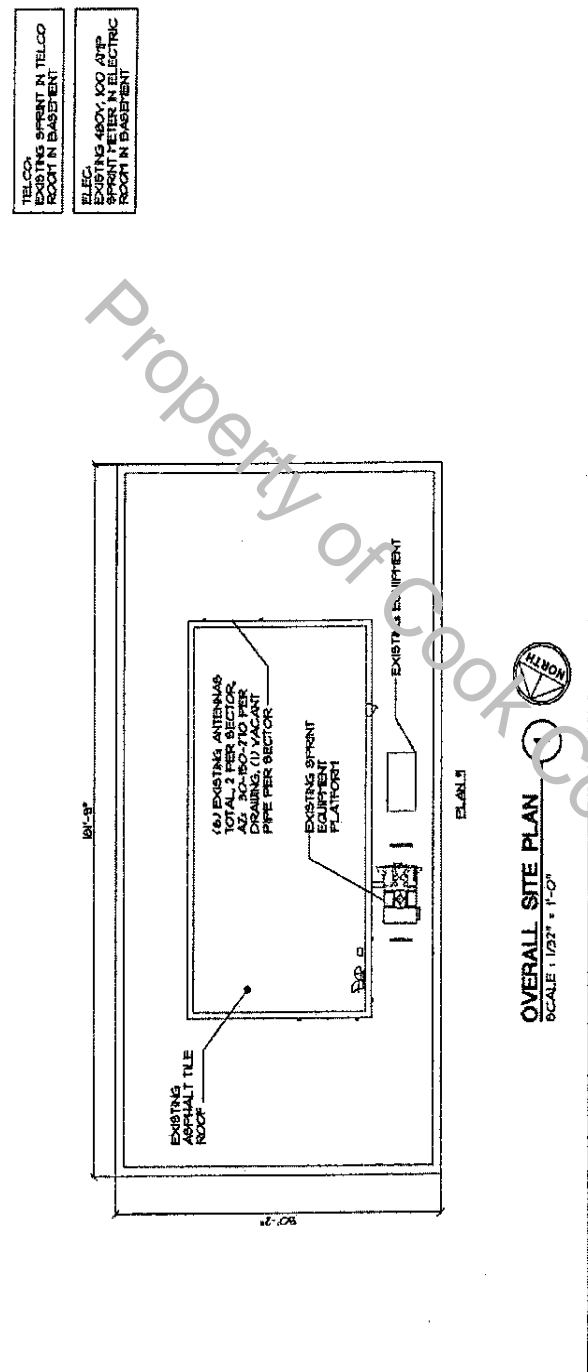

- GENERAL NOTES**
1. ALL CONSTRUCTION SHALL CONFORM TO CURRENT LOCAL, STATE AND FEDERAL CODES
 2. ALL ELEVATIONS SHOWN HAVE BEEN TAKEN FROM AVAILABLE RECORDS FROM SPRINT AND IF ANY DISCREPANCIES ARE FOUND, THEY HAVE BEEN TAKEN FROM AVAILABLE RECORDS.
 3. ALL PROPERTY LINES AND EASEMENTS SHOWN HAVE BEEN TAKEN FROM AVAILABLE RECORDS.
 4. ALL PROPERTY LINES AND EASEMENTS SHOWN HAVE BEEN TAKEN FROM AVAILABLE RECORDS.
 5. CONTRACTOR SHALL TAKE APPROPRIATE CARE TO PROTECT EXISTING PROPERTY AND UTILITIES. ANY DAMAGE TO EXISTING UTILITIES SHALL BE REPAIRED OR REPLACED AT THE CONTRACTOR'S EXPENSE. ANY DAMAGED ITEMS TO SPRINT OR WFI DIRECTION
 6. CONTRACTOR SHALL COORDINATE ALL CONSTRUCTION RELATED ACTIVITIES WITH WFI CONSTRUCTION MANAGER AS REQUIRED TO NOT DISRUPT EXISTING SITE
 7. CONTRACTOR SHALL COORDINATE ALL CONSTRUCTION RELATED ACTIVITIES WITH WFI CONSTRUCTION MANAGER AS REQUIRED TO NOT DISRUPT EXISTING SITE
 8. ALL MAJOR CONSTRUCTION PROCEDURE DISTURBANCES SHALL BE APPROVED BY WFI IN ADVANCE OF PROCEDURES
 9. ALL MAJOR CONSTRUCTION PROCEDURE DISTURBANCES SHALL BE APPROVED BY WFI IN ADVANCE OF PROCEDURES
 10. CONTRACTOR SHALL VERIFY ALL EXISTING BUILDING SUPPORT STRUCTURES PRIOR TO CONSTRUCTION AND REPORT ANY CONCERNS OR DISCREPANCIES TO ENGINEER IMMEDIATELY
 11. CONTRACTOR SHALL BE RESPONSIBLE FOR ALL SAFETY AND REPAIR OF ANY DAMAGED EXISTING BUILDING STRUCTURES CAUSED BY THIS SCOPE OF WORK
 12. CONTRACTOR SHALL BE RESPONSIBLE FOR ALL SAFETY AND REPAIR OF ANY DAMAGED EXISTING BUILDING STRUCTURES CAUSED BY THIS SCOPE OF WORK
 13. CONTRACTOR SHALL NOT DISRUPT ANY UTILITY SERVICES WITHOUT PROPER PERMISSIONS
 14. CONTRACTOR SHALL NOT LEAVE ANY TOOLS, DEBRIS OR SUPPLIES DURING OFF-HOURS
 15. CONTRACTOR SHALL NOT LEAVE ANY DEBRIS WHEN COMPLETE WITH SCOPE OF WORK
 16. CONTRACTOR SHALL HALL ALL GARBAGE AND DEBRIS OFF SITE
 17. CONTRACTOR SHALL PROVIDE OSHA APPROVED SIGNAGE AS REQUIRED
 18. ANY NECESSARIES SHALL BE REPORTED TO WFI WITHIN 2 HOURS
 19. LANDLORD WITHOUT THE PROPER PERMISSIONS
 20. CONTRACTOR SHALL RESTORE AND REPAIR ANY DAMAGED AREAS CAUSED BY CONSTRUCTION
 21. CONTRACTOR SHALL VERIFY ALL EXISTING BURIED AND OVERHEAD UTILITIES PRIOR TO EXCAVATION. CONTRACTOR SHALL REPAIR ALL DAMAGED UTILITIES AT HIS OWN COST AND COORDINATE ANY REPAIRS WITH RESPECTIVE UTILITY COMPANY.

Exhibit A

CH03XC242



UNOFFICIAL COPY

Sprint Site ID: CH03XC242-C

LESSOR NOTARY BLOCK

INDIANA)
STATE OF ILLINOIS)
NOBLE) ss.
COUNTY OF COOK)

The foregoing instrument was (choose one) attested or acknowledged before me this 23rd day of July, 2008, by (choose one)

_____ as an individual,
 Brian Hull, as VP and GM of

Emergency Radio Service, Inc., an Indiana corporation, on behalf of the corporation, or

_____, partner or agent on behalf of _____, a _____ partnership.

In witness whereof I hereunto set my hand and official seal.

My Commission Expires: 10-26-2015

Anne M Ringle
NOTARY PUBLIC ANNE M. RINGLER
Residing in Noble County, IN

LESSEE NOTARY BLOCK

STATE OF KANSAS)
) ss.
COUNTY OF JOHNSON)

ACKNOWLEDGMENT BY CORPORATION PURSUANT TO UNIFORM ACKNOWLEDGMENT ACT

The foregoing instrument was acknowledged before me this 16th day of July, 2008, by Jon L. Geisel, Supervisor, Contract Negotiations, on behalf of SprintCom, Inc..

In witness whereof I hereunto set my hand and official seal.

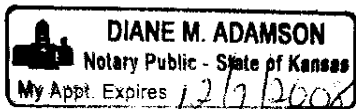

Diane M Adamson
NOTARY PUBLIC
Diane M Adamson