

UNOFFICIAL COPY

IS INSTRUMENT WAS PREPARED BY:

Klein Thorpe & Jenkins, Ltd.
20 North Wacker Drive
Suite 1660
Chicago, IL 60606
George A. Wagner

(2881-005)



Doc# 2117219016 Fee \$88.00

KAREN A. YARBROUGH

COOK COUNTY CLERK

DATE: 06/21/2021 11:04 AM PG: 1 OF 10

AFTER RECORDING RETURN TO:

RECORDER'S BOX 324

**BACKYARD DRAINAGE PROGRAM
IMPROVEMENT AND CONSTRUCTION AGREEMENT**

This Agreement (hereinafter the "Agreement") entered into this 6 day of MAY, 2021, by and between the Village of Mount Prospect, an Illinois home rule municipal corporation, Cook County, Illinois (hereinafter the "Village"), and MARIUS OLTEANU, of 919 I Oka Avenue, Mount Prospect, Illinois (hereinafter the "Property Owner"), the record property owner of the property legal described as follows:

Lot 13 in Block 4 in Lonquist Gardens, being a subdivision of the Northeast 1/4 of Section 14, Township 41 North, Range 11, east of the Third Principal Meridian as recorded on November 20, 1945 as Document Number 13663132.

Common address: 919 I Oka Avenue
PIN: 08-14-208-010

(hereinafter the "Property").

RECITALS

WHEREAS, The Village of Mount Prospect has adopted a Backyard Drainage Program which is intended to promote drainage of surface storm water to alleviate flooding in residential backyards in the Village; and

WHEREAS, the Village and the Property Owner (sometimes referred to as "Party" or "Parties") recognize that there are backyard drainage problems on the Property and are desirous to improve the drainage of surface storm water from that backyard.

UNOFFICIAL COPY

NOW THEREFORE, in consideration of the above Recitals, which are made a part hereof, and other good and valuable consideration, the Parties hereby agree to the following terms:

1. Contract for Construction/Permits. The Village will award a contract (hereinafter the "Contract") for the construction of certain drainage facilities (hereinafter the "Improvements"), as described on the approved plan, titled 2021 Backyard Drainage Program, dated April, 2021, a copy of which plan is attached hereto and incorporated herein as Exhibit A (hereinafter the "Plans"), and in accordance with the specifications for the Improvements included in the Contract (hereinafter the "Specifications"), the Specifications being incorporated herein by reference as if fully set forth.
2. Property Owner Participation of Construction Costs. The Property Owner shall be responsible for 25% of the total cost for construction, with an upper limit of \$5,000. The Village shall be responsible for all other construction costs. The Property Owner shall be required to provide payment along with this executed agreement to be eligible for the 2021 Backyard Drainage Program. In the event that the actual construction costs are lower than the estimated, resulting in the Property Owner's responsibility to be less than what was paid, the Village shall refund to the Property Owner so that the Property Owner's responsibility does not exceed 25% of the total construction cost.
3. Marking of Underground Facilities. Prior to beginning construction of the Improvements, the Property Owner shall mark out the locations of any underground facilities on the Property, including, but not limited to, sprinkler heads, sprinkler lines, drainage pipes and gas or electric yard light lines, to identify any potential conflicts with the proposed Improvements.
4. Construction of Improvements. The Village shall, at its sole cost, cause the Improvements to be constructed in accordance with the Plans and the Specifications, and provide engineering inspections during construction.
5. Restoration. As soon as practicable after construction of the Improvements, the Village shall be responsible for the restoration of any areas damaged by the construction of the Improvements, as the Village so determines (hereinafter the "Restoration"). Lawn areas will be restored with sod; driveways and sidewalks will be replaced with material similar to that, which is removed.
6. Maintenance Responsibilities. Upon acceptance of the Improvements, as hereinafter described, the Improvements shall be maintained (hereinafter the "Maintenance Responsibilities"), as follows:
 - a. The Village shall be responsible for the continuing care, management, and maintenance of the Improvements from, and including, the Catch Basin with restrictor (hereinafter the "Catch Basin") to the connection at the Village's sewer main.
 - b. The Property Owner shall be responsible for the continuing care, management, and maintenance of the Improvements from the Catch Basin to the end of the Improvements on the Property, including the rain garden, but excluding the Catch Basin. To insure continued compliance with the approved plan, following construction, the Village will periodically inspect the installed system.

UNOFFICIAL COPY

- c. The Village of Mount Prospect and its contractors will make every effort to protect private property trees from injury during the project. However, it should be recognized that excavation near trees will result in some root loss. The Village recommends periodic follow up inspections by a qualified professional arborist to monitor tree health and safety.
7. Temporary Construction Easement. Effective on the Effective Date, the Property Owner grants a temporary construction easement to the Village, its employees, agents, and contractors, on, over, under and across the Property to permit the construction of the Improvements and Restoration (hereinafter the "Temporary Construction Easement"). Said easement shall terminate upon acceptance of the Improvements, as described below.
 8. Acceptance of Improvements. Upon completion of the Improvements and Restoration, the Village shall determine if the Improvements conform with the approved Plan and Specifications. Upon such determination, the Village shall accept the Improvements and execute a written Notice of Acceptance, which shall confirm its acceptance of the Improvements, and thereby terminate the Temporary Construction Easement and begin the Maintenance Responsibilities. A copy of the Notice of Acceptance shall be provided to the Property Owner and recorded by the Village in the Cook County Recorder's Office.
 9. Termination. The Parties agree that, prior to beginning construction of the Improvements, the Village may terminate this Agreement, without penalty of any kind, in the event that funding for the Improvements is not available, as determined solely by the Village. The Village shall provide a written notice of such termination to the Property Owner and a full refund to the Property Owner within 30 days. Work not started before January 1, 2022 will result in termination and refund unless previously agreed upon by both parties in writing.
 10. Indemnification by Property Owner/No Warranty. The Property Owner agrees to indemnify, defend, and hold harmless the Village, its officers, officials, employees, and agents (hereinafter the "Village indemnities"), from any and all losses, claims, causes of action, damages, liability or expenses (including reasonable attorneys fees and court costs) of any kind, paid or incurred by the Village, that are in any way related to the Improvements or this Agreement. The Property Owner acknowledges that the Village does not warrant the effectiveness of the Improvements in alleviating water on the Property.
 11. Indemnification by Village. The Village agrees to indemnify, defend, and hold harmless the Property Owner from any and all losses, claims, causes of action, damages, liability or expenses (including reasonable attorneys fees and court costs) of any kind, paid or incurred by the Property Owner, that are caused by the Village's use of the Construction Easement to construct the Improvements, except to the extent caused by the negligent or willful or wanton acts of the Property Owner.
 12. Binding Effect. This Agreement shall run with the land and the covenants, agreements, terms, conditions, obligations, rights and interest herein contained or provided for shall be likewise binding upon and shall inure to the benefit of the Parties, their heirs, executors, successors, grantees, lessees and assigns. This Agreement shall be recorded by the Village in the Cook County Recorder's Office.

UNOFFICIAL COPY

13. Notice. Any and all notices given in connection with this Agreement shall be deemed adequately given only if in writing and addressed to the party for whom such notices are intended at the address set forth below. Any notice or demand shall be mailed by registered mail, certified mail, or personally delivered to the proper address. The customary receipt signed or refused by the party to whom notice is directed shall be conclusive evidence of such service. Notice shall be deemed given when delivered, if given by personal delivery, otherwise when received, as evidenced by receipt or refusal, as applicable. Any and all notices referred to in this Agreement, or that either party desires to give to the other, shall be addressed as follows:

For Village of Mount Prospect:

Village Engineer
 Village of Mount Prospect
 1700 W. Central Road
 Mount Prospect, Illinois 60056

For the Property Owner:

To the Property Owner at the Property or to the last name and address shown on the most recent real estate tax bill issued by the Cook County Treasurer.

Any party hereto may, by notice given hereunder, designate any further or different addresses to which subsequent notices or other communications shall be sent.

14. Venue. This Agreement shall be governed, interpreted, construed, and enforced in accordance with the laws of the State of Illinois.
15. Execution in Counterparts. This Agreement may be executed in any number of counterparts, each of which shall be deemed an original, but all of which together shall constitute one and the same instrument.
16. Amendment. This Agreement may be modified, amended or annulled only by the written agreement of the parties that is executed and delivered by authorized representatives of the parties.
17. Complete Agreement. This Agreement embodies the entire understanding of the Parties and there are no further or other agreements or understandings, written or oral, in effect between the Parties relating to the subject matter hereof.
18. Severability. Wherever possible, each provision of this Agreement shall be interpreted in such manner as to be effective and valid under applicable law, but if any provision of this Agreement shall be prohibited by or invalid under applicable law, such provision shall be ineffective to the extent of such prohibition or invalidity, without invalidating the remainder of such provision or the remaining provisions of this Agreement.
19. Captions. Paragraph headings are for convenience only, and in no way define or limit the scope and content of this Agreement.

UNOFFICIAL COPY

- 20. Lender Requirements. In the event that the Landlord has a mortgage lien on the Property, the Property Owner is responsible for compliance with any lender requirements in regard to this Agreement.
- 21. Effective Date: The Effective Date of this Agreement shall be the date last signed by the Village.

IN WITNESS WHEREOF, the Parties have executed this Agreement.

Property Owner(s).

 _____ Signature	<u>MARIUS OLTEANU</u> _____ Name (Please print or type)	<u>05/06/2021</u> _____ Date
_____ Signature	_____ Name (Please print or type)	_____ Date

STATE OF ILLINOIS)
)
) ss.
COUNTY OF COOK)

I, Joan M Brown, a notary Public in and for the said County in the aforesaid State, do hereby certify that Marius Olteanu and _____ personally known to me to be the same persons whose names are subscribed to the foregoing instrument, appeared before me this day in person, and acknowledged that they executed and delivered the said instrument as their own free and voluntary acts and deeds for the uses and purposes set forth.

GIVEN under my hand and official seal, this 6 day of May, 2021.

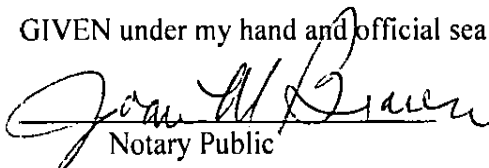

Notary Public

5.7.22

Commission Expiration Date

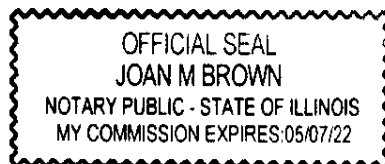

UNOFFICIAL COPY

ACCEPTED: VILLAGE OF MOUNT PROSPECT

By: *Paul Wm. Hoefert*
Paul Wm. Hoefert, Village President

Attest: *Karen M. Agoran*
Karen Agoranos, Village Clerk

Date: 6/2/2021

Date: 6/2/2021

STATE OF ILLINOIS)
) ss.
COUNTY OF COOK)

I, the undersigned, a Notary Public, in and for the County and State aforesaid, DO HEREBY CERTIFY that **PAUL WM. HOEFERT**, personally known to me to be the Mayor of the **VILLAGE OF MOUNT PROSPECT, AN ILLINOIS HOME RULE MUNICIPAL CORPORATION** (the "Village") and **KAREN AGORANOS**, personally known to me to be the Village Clerk, personally known to me to be the same persons whose names are subscribed to the foregoing instrument, appeared before me this day in person and severally acknowledged that as such Mayor and Village Clerk, they signed and delivered the said instrument and caused the corporate seal of the Village to be affixed thereto, pursuant to authority given by the Village Board of Trustees, and as their free and voluntary act, and as the free and voluntary act and deed of the Village, for the uses and purposes therein set forth.

GIVEN under my hand and official seal, this 2 day of June, 2021.

Doreen C Jarosz
Notary Public

4-13-22
Commission Expiration Date

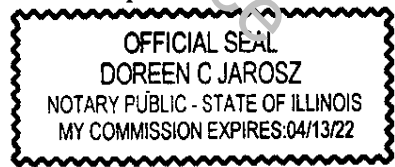

UNOFFICIAL COPY

EXHIBIT A IMPROVEMENTS

Site Plan

Catch Basin w/ Restrictor Detail

Rain Garden Detail

Property of Cook County Clerk's Office

COOK COUNTY CLERK OFFICE
RECORDING DIVISION
118 N. CLARK ST. ROOM 120
CHICAGO, IL 60602-1387

COOK COUNTY CLERK OFFICE
RECORDING DIVISION
118 N. CLARK ST. ROOM 120
CHICAGO, IL 60602-1387

COOK COUNTY CLERK OFFICE
RECORDING DIVISION
118 N. CLARK ST. ROOM 120
CHICAGO, IL 60602-1387

UNOFFICIAL COPY

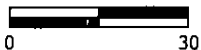
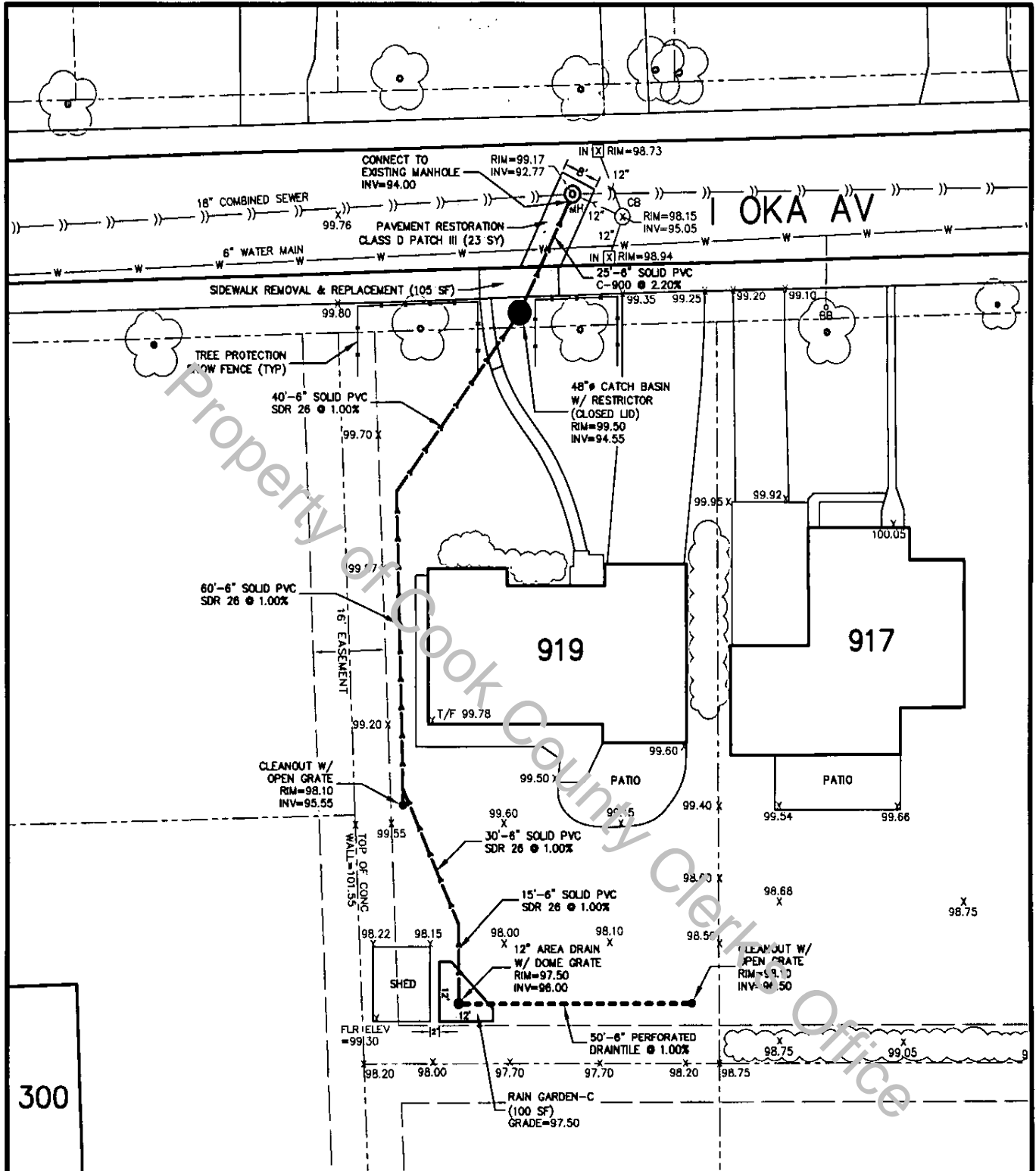

BENCHMARK:
 NORTHEAST UPPER BOLT OF
 FIRE HYDRANT @ 913 I OKA
 ELEV=100.00

NOTES:

1. REPLACE SIDEWALK DISTURBED BY STORM SEWER INSTALLATION (50 SF MAX.)
2. REPLACE CURB AND GUTTER DISTURBED BY STORM SEWER INSTALLATION (15' MAX.)
3. IF ANY EXCAVATION IS NECESSARY WITHIN THE TREE PROTECTION AREA, THE CONTRACTOR MUST CONTACT THE FORESTRY DIVISION PRIOR TO BEGINNING WORK.
4. UNLESS OTHERWISE NOTED ON THE PLAN, SUMP PUMPS AND DOWNSPOUTS SHALL NOT BE CONNECTED TO THE DRAINTILE, STORM SEWER OR RAIN GARDEN.



Village of Mount Prospect
 Public Works Department
 1700 W Central Rd

919 I OKA AVE

Design: CML

Drawing: RLH

Scale: 1:30

Date: 1-22-21

Sheet: 1 of 1

UNOFFICIAL COPY

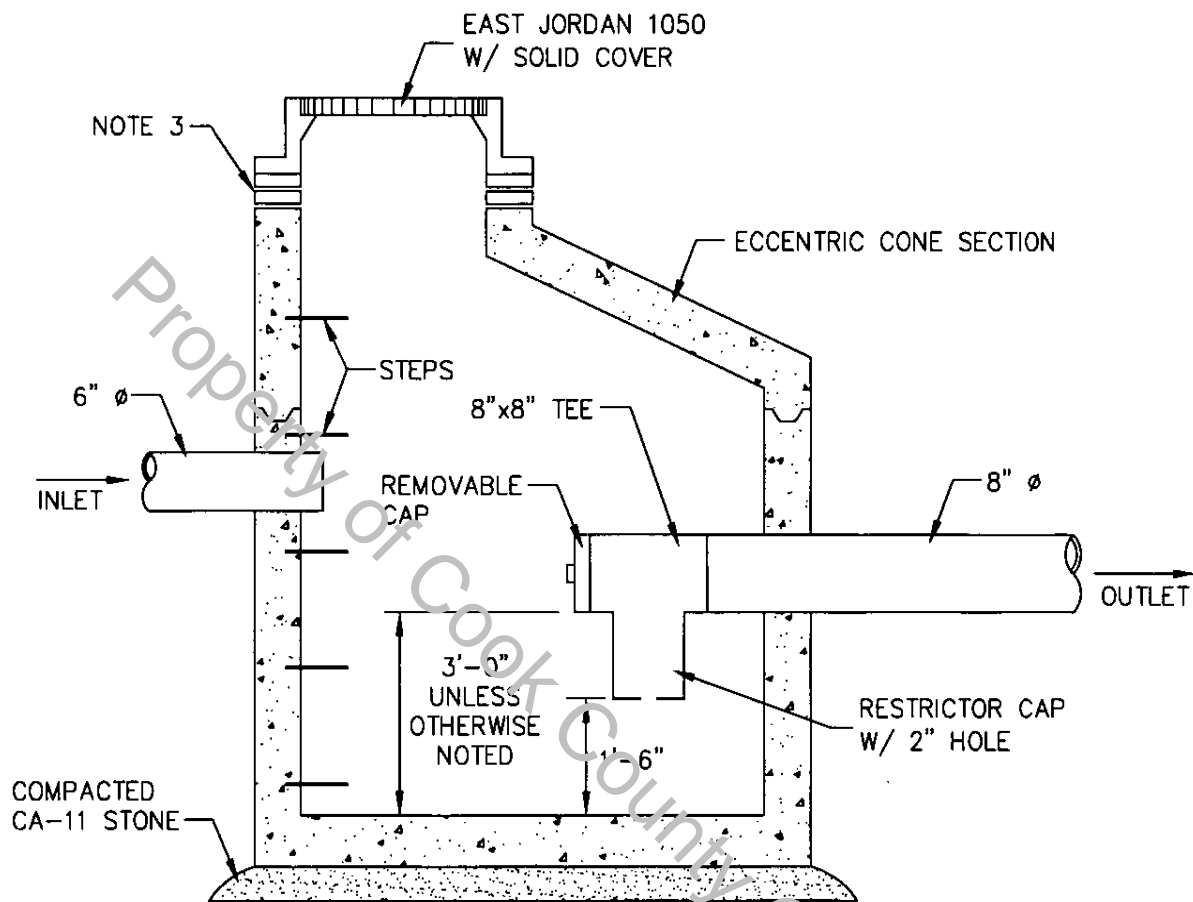

NOTES:

1. PRECAST SECTIONS TO BE JOINED WITH TONGUE AND GROOVE JOINTS SEALED WITH MASTIC TYPE BITUMINOUS JOINTING COMPOUND.
2. PRECAST CONCRETE BARREL SECTION ASTM C-478 AND ASTM C-443
3. PRECAST CONCRETE RING CONSTRUCTION ASTM C-478-64T ADJUSTMENT TO 12" MAXIMUM, USING THE MINIMUM NEEDED TO ACHIEVE THE DESIRED ELEVATION WITH 3 RINGS MAXIMUM. RUBBER NOISE RINGS SHALL BE USED IN ALL TRAFFIC AREAS.
4. STEPS SHALL BE EMBEDDED INTO WALL A MINIMUM OF 3" AND SHALL NOT BE EXTENDED ON THE OUTSIDE.
5. MINIMUM DIAMETER (D) SHALL BE 48" UNLESS OTHERWISE NOTED ON THE PLAN.
6. A FACTORY INSTALLED WATERTIGHT "RUBBER BOOT SEAL" CONFORMING TO ASTM C-923 SHALL BE PRECAST INTO ALL PIPE OPENINGS WHEN CATCH BASINS ARE TIED INTO COMBINED SEWER SYSTEM.



Village of Mount Prospect
Public Works Department
1700 W Central Rd

CATCH BASIN WITH RESTRICTOR DETAIL

Scale: None

Last Revised: 12-2019

UNOFFICIAL COPY

AREA	A	B	C	D	E	F
50 ft ²	3	8	3	10	3	8
100 ft ²	3	12	3	18	5	8
200 ft ²	4	17	4	24	8	10

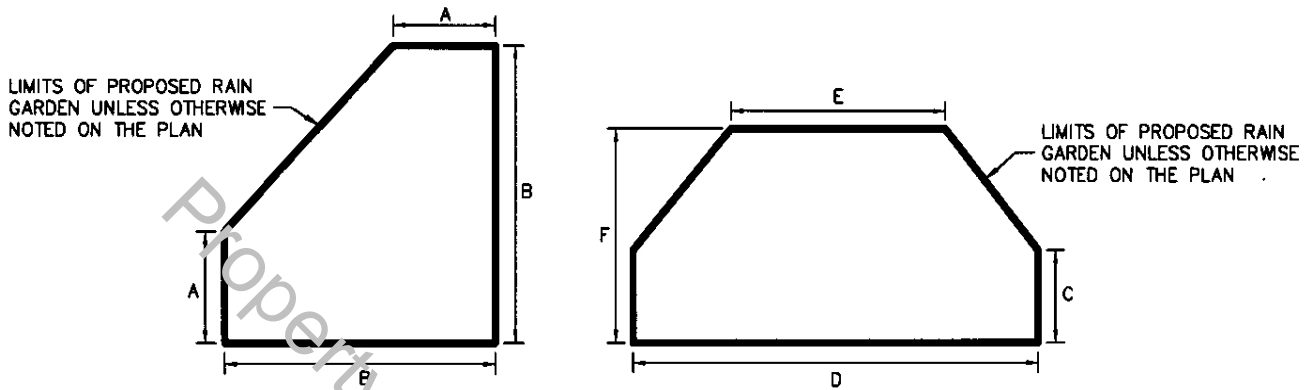

PLAN

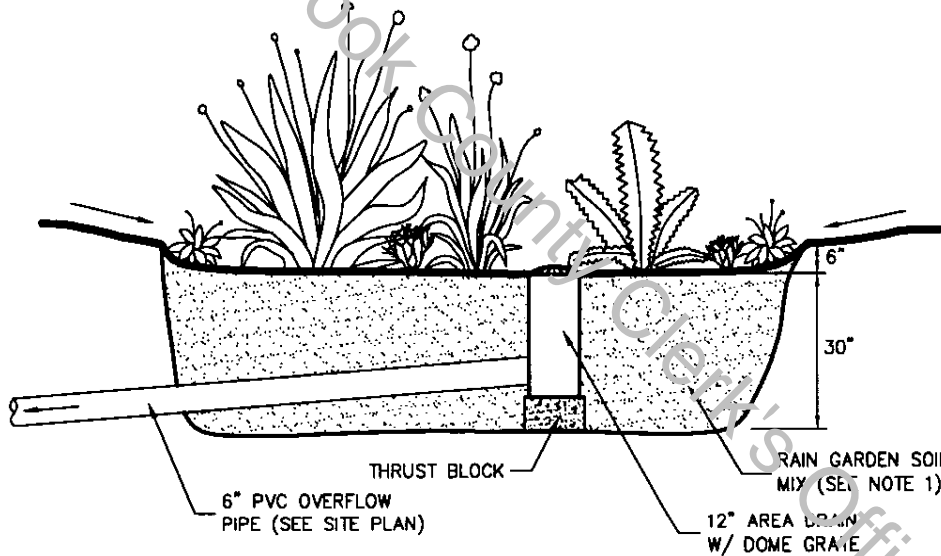

SECTION

NOTES:

1. THE RAIN GARDEN SOIL MIX SHALL CONSIST OF:
 - 60% SAND
 - 25% TOP SOIL
 - 15% COMPOST OR PEAT MOSS
2. PLANTS FOR RAIN GARDEN TO BE SELECTED FROM APPROVED LIST.
3. ROUGHEN SIDES OF EXCAVATED HOLE PRIOR TO BACKFILLING.



Village of Mount Prospect
Public Works Department
1700 W Central Rd

RAIN GARDEN-C DETAIL

Scale: None

Last Revised: 12-2019