

# UNOFFICIAL COPY

## ENVIRONMENTAL DISCLOSURE DOCUMENT FOR TRANSFER OF REAL PROPERTY

94960844

The following information is provided pursuant to the Responsible Property Transfer Act of 1988

For Use By County

Seller: Shell Oil Co.

Recorder's Office

Buyer: Holy Cross Hospital

County

Document No.: \_\_\_\_\_

Date

Doc. No.

Vol. \_\_\_\_\_ Page \_\_\_\_\_

Rec'd by: \_\_\_\_\_

### I. PROPERTY IDENTIFICATION:

A. Address of property: 6084 South Archer Ave., Chicago Lake \_\_\_\_\_  
Street City or Village Township

Permanent Real Estate Index No.: 19-08-417-069-0000

### B. Legal Description:

Section 8 Township 38 North Range 13

Enter or attach current legal description in this area:

LOTS 17 TO 24, BOTH INCLUSIVE, IN BLOCK 23 IN CRANE AND ARCHER AVENUE HOME ADDITION TO CHICAGO, A SUBDIVISION IN THE SOUTH EAST 1/4 OF SECTION 8, TOWNSHIP 38 NORTH, RANGE 13 EAST OF THE THIRD PRINCIPAL MERIDIAN, LYING NORTHERLY OF THE CENTER LINE OF ARCHER AVENUE, IN COOK COUNTY, ILLINOIS.

COOK COUNTY, ILLINOIS  
FILED FOR RECORD

94 NOV 10 PM 2:57

94960844

Prepared by: S. L. Harris  
Shell Oil Co name  
1415 W. 22nd St.  
Oak Brook, address IL 60305

Return to: Same name \_\_\_\_\_  
address \_\_\_\_\_

### LIABILITY DISCLOSURE

Transfers and transferees of real property are advised that their ownership or other control of such property may render them liable for any environmental clean-up costs whether or not they caused or contributed to the presence of environmental problems associated with the property.

### C. Property Characteristics:

Lot Size 24,841 SF Acreage \_\_\_\_\_

Check all types of improvement and uses that pertain to the property:

Apartment building (6 units or less)

Industrial building

Commercial apartment (over 6 units)

Farm, with buildings

Store, office, commercial building

Other, specify former service station

### II. NATURE OF TRANSFER:

Yes No

A. (1) Is this a transfer by deed or other instrument of conveyance?  \_\_\_\_\_

(2) Is this a transfer by assignment of over 25% of beneficial interest of an Illinois land trust? \_\_\_\_\_

(3) A lease exceeding a term of 40 years? \_\_\_\_\_

(4) A mortgage or collateral assignment of beneficial interest? \_\_\_\_\_

75 17 629 DN

2998

94960844

94960844

# UNOFFICIAL COPY

## B. SITE INFORMATION UNDER OTHER OWNERSHIP OR OPERATION

1. Provide the following information about the previous owner or any entity or person the transferor leased the site to or otherwise contracted with for the management of the site or real property:

Name: Chicago Title & Trust Co. as Trustee U/T/A #1082463, dated 08/30/82

171 N. Clark St., Chicago, IL 60601

Type of business/  
or property usage: Service Station operated by Gas City, beneficiary of  
Trust #1082463 dated 08/30/82.

2. If the transferor has knowledge, indicate whether the following existed under prior ownerships, leaseholds granted by the transferor, other contracts for management or use of the facilities or real property:

	YES	NO		YES	NO
Landfill	_____	<u>X</u>	Injection Wells	_____	<u>X</u>
Surface Impoundment	_____	<u>X</u>	Wastewater Treatment Units	_____	<u>X</u>
Land Treatment	_____	<u>X</u>	Septic Tanks	_____	<u>X</u>
Waste Pile	_____	<u>X</u>	Transfer Stations	_____	<u>X</u>
Incinerator	_____	<u>X</u>	Waste Recycling Operations	_____	<u>X</u>
Storage Tank (Above Ground)	_____	<u>X</u>	Waste Treatment Detoxification	_____	<u>X</u>
Storage Tank (Underground)	<u>X</u>	_____	Other Land Disposal Area	_____	<u>X</u>
Container Storage Area	_____	<u>X</u>			

## V. CERTIFICATION

A. Based on my inquiry of those persons directly responsible for gathering the information, I certify that the information submitted is, to the best of my knowledge and belief, true and accurate.

signature

S. L. Harris

type or print name

TRANSFEROR OR TRANSFERORS (or on behalf of Transferor)

B. This form was delivered to me with all elements completed on

September 1 1994

HOLY CROSS HOSPITAL

By: [Signature]

signature

type or print name

TRANSFeree OR TRANSFerees (or on behalf of Transferee)

C. This form was delivered to me with all elements completed on

\_\_\_\_\_ 19\_\_\_\_\_

signature

type or print name

LENDER

(Ch. 30, par. 906)

# UNOFFICIAL COPY

3. Has the transferor ever conducted operations on the property which involved the generation, transportation, storage, treatment or disposal of "hazardous or special wastes", as defined by the federal Resource Conservation and Recovery Act and the Illinois Environmental Protection Act?

Yes  No

4. Are there any of the following specific units (operating or closed) at the property which are or were used by the transferor to manage waste, hazardous wastes, hazardous substances or petroleum?

	YES	NO		YES	NO
Landfill	<input type="checkbox"/>	<input checked="" type="checkbox"/>	Injection Wells	<input type="checkbox"/>	<input checked="" type="checkbox"/>
Surface Impoundment	<input type="checkbox"/>	<input checked="" type="checkbox"/>	Wastewater Treatment Units	<input type="checkbox"/>	<input checked="" type="checkbox"/>
Land Treatment	<input type="checkbox"/>	<input checked="" type="checkbox"/>	Septic Tanks	<input type="checkbox"/>	<input checked="" type="checkbox"/>
Waste Pile	<input type="checkbox"/>	<input checked="" type="checkbox"/>	Transfer Stations	<input type="checkbox"/>	<input checked="" type="checkbox"/>
Incinerator	<input type="checkbox"/>	<input checked="" type="checkbox"/>	Waste Recycling Operations	<input type="checkbox"/>	<input checked="" type="checkbox"/>
Storage Tank (Above Ground)	<input type="checkbox"/>	<input checked="" type="checkbox"/>	Waste Treatment Detoxification	<input type="checkbox"/>	<input checked="" type="checkbox"/>
Storage Tank (Underground)	<input checked="" type="checkbox"/>	<input type="checkbox"/>	Other Land Disposal Area	<input type="checkbox"/>	<input checked="" type="checkbox"/>
Container Storage Area	<input type="checkbox"/>	<input checked="" type="checkbox"/>			

If there are "YES" answers to any of the above items and the transfer is other than a mortgage or collateral assignment of beneficial interest, attach a site plan which identifies the location of each unit, such site plan to be filed with the Environmental Protection Agency along with this disclosure document.

5. Has the transferor ever held any of the following in regard to this real property?

- a. Permits for discharges of wastewater to waters of the State. Yes \_\_\_\_\_ No
- b. Permits for emissions to the atmosphere. Yes \_\_\_\_\_ No
- c. Permits for any waste storage, waste treatment or waste disposal operation. Yes \_\_\_\_\_ No

6. Has the transferor had any wastewater discharges (other than sewage) to a publicly owned treatment works?

Yes \_\_\_\_\_ No

7. Has the transferor taken any of the following actions relative to this property?

- a. Prepared a Chemical Safety Contingency Plan pursuant to the Illinois Chemical Safety Act. Yes \_\_\_\_\_ No
- b. Filed an Emergency and Hazardous Chemical Inventory Form pursuant to the federal Emergency Planning and Community Right-to-Know Act of 1986. Yes \_\_\_\_\_ No
- c. Filed a Toxic Chemical Release Form pursuant to the federal Emergency Planning and Community Right-to-Know Act of 1986. Yes \_\_\_\_\_ No

8. Has the transferor or any facility on the property or the property been the subject of any of the following State or federal governmental actions?

- a. Written notification regarding known, suspected or alleged contamination on or emanating from the property. Yes  No \_\_\_\_\_
- b. Filing an environmental enforcement case with a court or the Pollution Control Board for which a final order or consent decree was entered. Yes \_\_\_\_\_ No
- c. If item b. was answered by checking Yes, then indicate whether or not the final order or decree is still in effect for this property. Yes \_\_\_\_\_ No \_\_\_\_\_

9. Environmental Releases During Transferor's Ownership

- a. Has any situation occurred at this site which resulted in a reportable "release" of any hazardous substances or petroleum as required under State or federal laws? Yes  No \_\_\_\_\_
- b. Have any hazardous substances or petroleum, which were released, come into direct contact with the ground at this site? Yes  No \_\_\_\_\_
- c. If the answers to questions (a) and (b) are Yes, have any of the following actions or events been associated with a release on the property?

- Use of a cleanup contractor to remove or treat materials including soils, pavement or other surficial materials
- Assignment of in-house maintenance staff to remove or treat materials including soils, pavement or other surficial materials
- Designation, by the IEPA or the IESDA, of the release as "significant" under the Illinois Chemical Safety Act
- Sampling and analysis of soils
- Temporary or more long-term monitoring of groundwater at or near the site
- Impaired usage of an on-site or nearby water well because of offensive characteristics of the water
- Coping with fumes from subsurface storm drains or inside basements, etc.
- Signs of substances leaching out of the ground along the base of slopes or at other low points on or immediately adjacent to the site

10. Is the facility currently operating under a variance granted by the Illinois Pollution Control Board?

Yes \_\_\_\_\_ No

11. Is there any explanation needed for clarification of any of the above answers or responses? \_\_\_\_\_

BA. IESDA Number 890849

94960844

# UNOFFICIAL COPY

## B. (1) Identify Transferor:

Shell Oil Company, 777 Walker St., Houston, TX 77002  
Name and Current Address of Transferor

Name and Address of Trustee if this is a transfer of beneficial interest of a land trust.

Trust No.

## (2) Identify person who has completed this form on behalf of the Transferor and who has knowledge of the information contained in this form:

S. L. Harris, Env. R/E Rep., 1415 W. 22nd St., Oak Brook, IL 708/572-5724  
Name, Position (if any), and address Telephone No.

## C. Identify Transferee: Holy Cross Hospital, 2701 W. 68th St., Chicago, IL 60629 Name and Current Address of Transferee

### III. NOTIFICATION

Under the Illinois Environmental Protection Act, owners of real property may be held liable for costs related to the release of hazardous substances.

#### 1. Section 22.2(f) of the Act states:

"Notwithstanding any other provision or rule of law, and subject only to the defenses set forth in subsection (j) of this Section, the following persons shall be liable for all costs of removal or remedial action incurred by the State of Illinois as a result of a release or substantial threat of a release of a hazardous substance:

(1) The owner and operator of a facility or vessel from which there is a release or substantial threat of release of a hazardous substance;

(2) Any person who at the time of disposal, transport, storage or treatment of a hazardous substance owned or operated the facility or vessel used for such disposal, transport, treatment or storage from which there was a release or substantial threat of a release of any such hazardous substance;

(3) Any person who by contract, agreement, or otherwise has arranged with another party or entity for transport, storage, disposal or treatment of hazardous substances owned, controlled or possessed by such person at a facility there is a release or substantial threat of a release of such hazardous substances; and

(4) Any person who accepts or accepted any hazardous substances for transport to disposal, storage or treatment facilities or sites from which there is a release or a substantial threat of a release of a hazardous substance."

#### 2. Section 4(q) of the Act states:

"The Agency shall have the authority to provide notice to any person who may be liable pursuant to Section 22.2(f) of this Act for a release or a substantial threat of a release of a hazardous substance. Such notice shall include the identified response action and an opportunity for such person to perform the response action."

#### 3. Section 22.2(k) of the Act states:

"If any person who is liable for a release or substantial threat of release of a hazardous substance fails without sufficient cause to provide removal or remedial action upon or in accordance with a notice and request by the agency or upon or in accordance with any order of the Board or any court, such person may be liable to the State for punitive damages in an amount at least equal to, and not more than 3 times, the amount of any costs incurred by the State of Illinois as result of such failure to take such removal or remedial action. The punitive damage imposed by the Board shall be in addition to any costs recovered from such person pursuant to this Section and in addition to any other penalty or relief provided by this Act or any other law."

#### 4. Section 22.18(a) of the Act states:

"Notwithstanding any other provision or rule or law, except as provided otherwise in subsection (b), the owner or operator, or both, of an underground storage tank shall be liable for all costs of preventive action, corrective action and enforcement action incurred by the State of Illinois as a result of a release or a substantial threat of release of petroleum from an underground storage tank."

5. The text of the statutes set out above is subject to change by amendment. Persons using this form may update it to reflect changes in the text of the statutes cited, but no disclosure statement shall be invalid merely because it sets forth an obsolete or superseded version of such text.

### IV. ENVIRONMENTAL INFORMATION

#### Regulatory Information During Current Ownership

1. Has the transferor ever conducted operations on the property which involved the generation, manufacture, processing, transportation, treatment, storage or handling of "hazardous substances", as defined by the Illinois Environmental Protection Act? This question shall not be applicable for consumer goods stored or handled by a retailer in the same form, approximate amount, concentration and manner as they are sold to consumers, provided that such retailer does not engage in any commercial mixing (other than paint mixing or tinting of consumer sized containers), finishing, refinishing, servicing, or cleaning operations on the property.

Yes \_\_\_\_\_ No X

2. Has the transferor ever conducted operations on the property which involved the processing, storage or handling of petroleum, other than that which was associated directly with the transferor's vehicle usage?

Yes X No \_\_\_\_\_

541-EXC

FIGURE 3

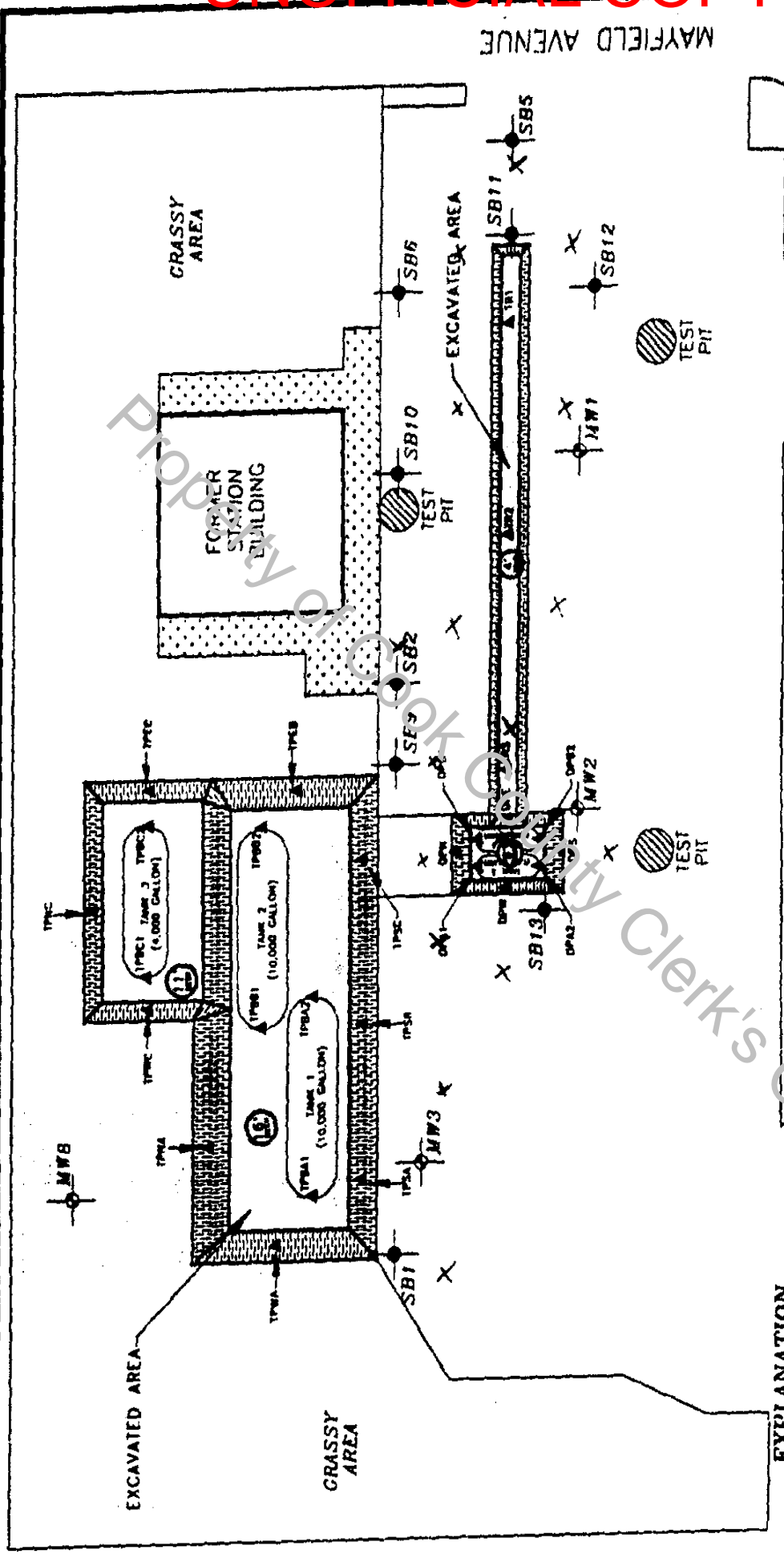

EXPLANATION

- MONITORING WELLS
- SOIL BORINGS
- ▲ SAMPLE POINTS

APPROX. SCALE 1" = 20'

ARCHER AVENUE X initial geoblogs points (17)

DATE	7-22-94	SCALE	1/8"
PROJECT NO.	08541	DATE	7/93
DESIGNED BY	C. KUMI	DATE	
CHECKED BY		DATE	
APPROVED BY	R. YODER	DATE	

SHELL SERVICE STATION  
6084 ARCHER AVENUE  
CHICAGO, ILLINOIS

FORMER UST LAYOUT  
AND SAMPLE LOCATIONS

ENGINEERING-SCIENCE  
DESIGN - RESEARCH - PLANNING

ES

94950844

UNOFFICIAL COPY

Property of Cook County Clerk's Office

11/11/2011