

UNOFFICIAL COPY



Chicago Title Insurance Company

WARRANTY DEED
ILLINOIS STATUTORY
JOINT TENANTS

99301164

4033/0219 03 001 Page 1 of 3
1999-03-29 14:13:35
Cook County Recorder 25.00



99301164

G 7798872 CTIC
10035C

THE GRANTOR(S) Richard J. Fiedler, Divorced and not since remarried of the City of Chicago, County of Cook, State of Illinois for and in consideration of TEN & 00/100 DOLLARS, and other good and valuable consideration to them in hand paid, CONVEY(S) and WARRANT(S) to Reynaldo Panganiban and Esmeralda Panganiban and Christine Panganiban

GRANTEE'S ADDRESS: , Chicago, Illinois

of the county of Cook, not as tenants in common, but as joint tenants, the following described Real Estate situated in the County of Cook in the State of Illinois, to wit:

SEE EXHIBIT "A" ATTACHED HERETO AND MADE A PART HEREOF

SUBJECT TO: lien of general taxes not yet payable; zoning laws and building ordinances; easements of record for utilities, drainage, public roads, highways and improvements; limitations and conditions imposed by the Illinois Condominium Property Act and condominium declarations, if applicable; party wall rights and agreements; covenants and restrictions of record. None of the foregoing exceptions to the warranties of this conveyance are violated by the existing improvements or the present use of the property or if they materially restrict the reasonable use of the property as Buyer's residence.

hereby releasing and waiving all rights under and by virtue of the Homestead Exemption Laws of the State of Illinois. TO HAVE AND TO HOLD said premises not as tenants in common, but as joint tenants forever.

Permanent Real Estate Index Number(s): 17-10-400-012-1554

Address(es) of Real Estate: 400 E. Randolph, Unit 2528, Chicago, Illinois

DATED this 19 day of March, 1999

Richard J. Fiedler
Richard J. Fiedler

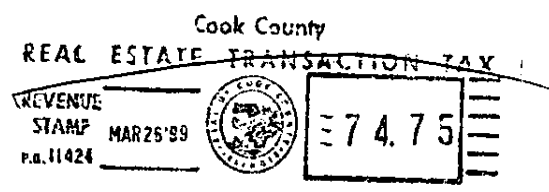
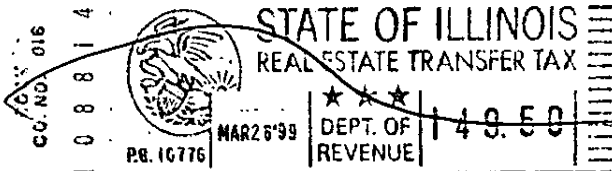

BOX 333-CTI

UNOFFICIAL COPY



STATE OF ILLINOIS
DEPARTMENT OF REVENUE
CHICAGO, ILLINOIS

Property of Cook County Clerk's Office

THE DEPARTMENT OF REVENUE, STATE OF ILLINOIS, has received from the State of Illinois for and in consideration of \$100,000.00, the right and title to the land described in the following description, to-wit: (1) to the north half of Section 36, Township 36 North, Range 10 East, Cook County, Illinois.

to the county of Cook, and in consideration of \$100,000.00, the right and title to the land described in the following description, to-wit: (2) to the south half of Section 36, Township 36 North, Range 10 East, Cook County, Illinois.

THE DEPARTMENT OF REVENUE, STATE OF ILLINOIS, has received from the State of Illinois for and in consideration of \$100,000.00, the right and title to the land described in the following description, to-wit: (3) to the north half of Section 36, Township 36 North, Range 10 East, Cook County, Illinois.

Department of Real Estate, State of Illinois, Chicago, Illinois
Telephone No. 312-443-1111

DEPARTMENT OF REVENUE, STATE OF ILLINOIS
CHICAGO, ILLINOIS

UNOFFICIAL COPY

STATE OF ILLINOIS, COUNTY OF Cook ss.

I, the undersigned, a Notary Public in and for said County, in the State aforesaid, DO HEREBY CERTIFY that Richard J. Fiedler, Divorced and not since remarried

personally known to me to be the same person(s) whose name(s) is subscribed to the foregoing instrument, appeared before me this day in person, and acknowledged that he signed, sealed and delivered the said instrument as his free and voluntary act, for the uses and purposes therein set forth, including the release and waiver of the right of homestead.

Given under my hand and official seal, this 1st day of March 1999

"OFFICIAL SEAL"
CHERYL ANN NUTLEY
Notary Public, State of Illinois
My Commission Expires 9/10/99

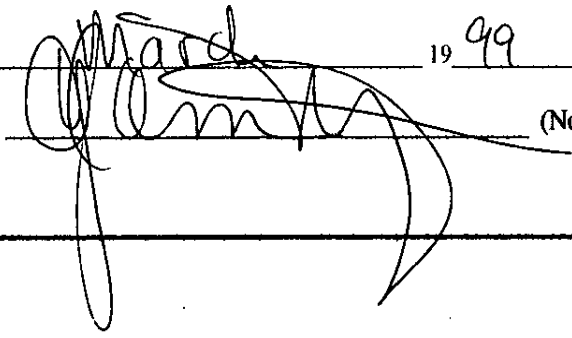

(Notary Public)

Prepared By: Law Offices of Barbara B. Bressler
929 Long Road
Glenview, Illinois 60025-3355

Mail To:
Barbara B. Bressler
929 Long Road
Glenview, Illinois 60025

Name & Address of Taxpayer:
Reynaldo Panganiban
400 E. Randolph, Unit 2528
Chicago, Illinois

★ 075397 ★
CITY OF CHICAGO ★
REAL ESTATE TRANSACTION TAX ★
★ DEPT. OF ★
★ REVENUE ★ MAR 26 '99 ★
★ P.B. 11187 ★
 900.00 ★

★ 075398 ★
CITY OF CHICAGO ★
REAL ESTATE TRANSACTION TAX ★
★ DEPT. OF ★
★ REVENUE ★ MAR 26 '99 ★
★ P.B. 11187 ★
 221.25 ★

Property of Cook County Clerk's Office

UNOFFICIAL COPY

OFFICE OF THE CLERK OF COOK COUNTY

I, the undersigned, County Clerk of Cook County, Illinois, do hereby certify that the foregoing is a true and correct copy of the original as the same appears in the records of the County Clerk of Cook County, Illinois.

Witness my hand and the seal of the County Clerk of Cook County, Illinois, at Chicago, Illinois, this _____ day of _____, 20__.

Property of Cook County Clerk's Office

County Clerk of Cook County, Illinois

Deputy County Clerk of Cook County, Illinois

Deputy County Clerk of Cook County, Illinois

Deputy County Clerk of Cook County, Illinois

UNOFFICIAL COPY

99301164

STREET ADDRESS: 400 EAST RANDOLPH UNIT 2528
CITY: CHICAGO COUNTY: COOK
TAX NUMBER: 17-10-400-012-1554

LEGAL DESCRIPTION:

UNIT NUMBER 2528 AS DELINEATED ON SURVEY OF CERTAIN LOTS IN THE PLAT OF LAKE FRONT PLAZA, A SUBDIVISION OF A PARCEL OF LAND LYING IN ACCRETIONS TO FRACTIONAL SECTION 10, TOWNSHIP 39 NORTH, RANGE 14 EAST OF THE THIRD PRINCIPAL MERIDIAN, ACCORDING TO THE PLAT THEREOF RECORDED APRIL 30, 1962, AS DOCUMENT NUMBER 18461961, CONVEYED BY DEED FROM ILLINOIS CENTRAL RAILROAD COMPANY TO AMERICAN NATIONAL BANK AND TRUST COMPANY OF CHICAGO, AS TRUSTEE UNDER TRUST NUMBER 17460, RECORDED MAY 7, 1962 AS DOCUMENT NUMBER 18467558, AND ALSO SUPPLEMENTAL DEED THERETO RECORDED DECEMBER 23, 1964 AS DOCUMENT NUMBER 19341545, WHICH SURVEY IS ATTACHED AS EXHIBIT 'A' TO DECLARATION OF CONDOMINIUM MADE BY AMERICAN NATIONAL BANK AND TRUST COMPANY OF CHICAGO, AS TRUSTEE UNDER TRUST AGREEMENT DATED APRIL 9, 1962 AND KNOWN AS TRUST NUMBER 17460, RECORDED IN THE OFFICE OF THE RECORDER OF COOK COUNTY, ILLINOIS AS DOCUMENT NUMBER 22453315, TOGETHER WITH AN UNDIVIDED .09510 PERCENT INTEREST IN THE PROPERTY DESCRIBED IN SAID DECLARATION OF CONDOMINIUM AFORESAID (EXCEPTING THE UNITS DEFINED AND SET FORTH IN THE DECLARATION OF CONDOMINIUM AND SURVEY) IN COOK COUNTY, ILLINOIS.

Property of Cook County Clerk's Office